

# *Diamant*

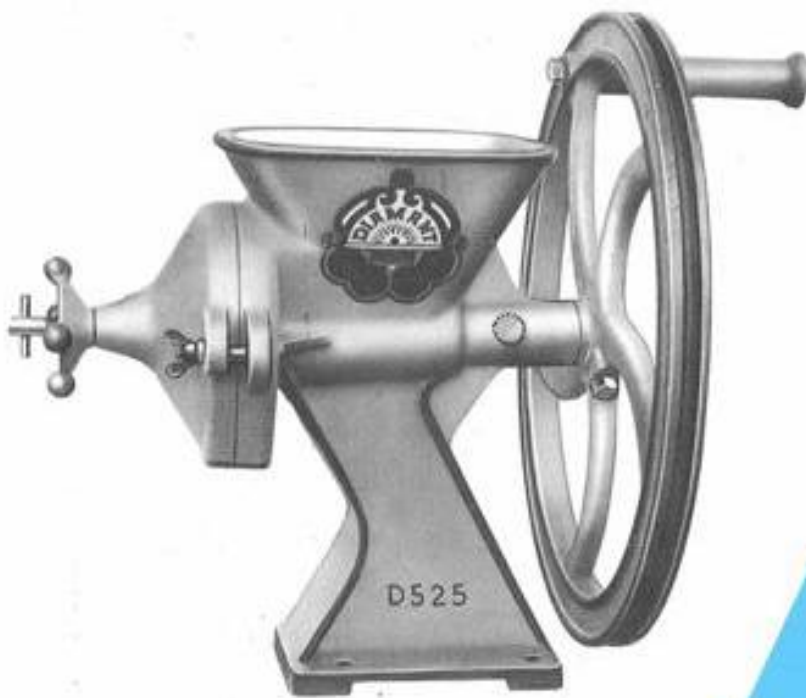

**HAND-OPERATED MILL  
TYPE D. 525**

**suitable for grinding of  
any kind of grain, corn,  
coffee, chemicals, spices,  
sugar etc. or  
similar dry or wet products.**

**DIAMANT HAND-OPERATED MILL TYPE D.525** is designed to meet the requirements for a small hand-operated mill, easy to operate by means of hand power or electric motor

The cast iron hopper is part of the mill itself and contains approx. 1.2 kg of grain. The mill casing and cover are made of cast iron and have long main thrust bearings. The shaft is sturdily designed and includes a feeder worm, which ensures a uniform feeding of the mill and at the same time pre-crushes the product. Therefore, you will always get the mill emptied after use.

The mill can be used for grinding of products with high moisture content as it can easily be opened and cleaned without any special tools. Due to the special force-feeding worm the mill is suited for grinding products with high oil content.

The flywheel is always disconnected when shipping in order to limit volume and freight expenses and in order to prevent damage of the shaft.

**Approx. average output per hour by handpower:**

Steel grinding discs - normal : 11-18 kg

**Shipping specifications - 1 mill in carton**

Net: 23 kg Grs: 29 kg Volume: 45 x 44 x 33 cm

## Motor-driven type

The mill can also be operated by an electric motor. The flywheel has a groove for V-belt drive.

We recommend a ½ HP or a 1 HP motor, 1400 r.p.m. and a pulley of 85 mm (3½") for the motor, making the rotation of the grinding disc approx 300 r.p.m.

## Steel grinding discs

The heart of the mill consists of the specially cast and hardened grinding discs. They are supplied in various types depending on the purpose. Type 14/15 for normal grinding, type 14a/15a for finer grinding, and type 16/17 for kibbling.

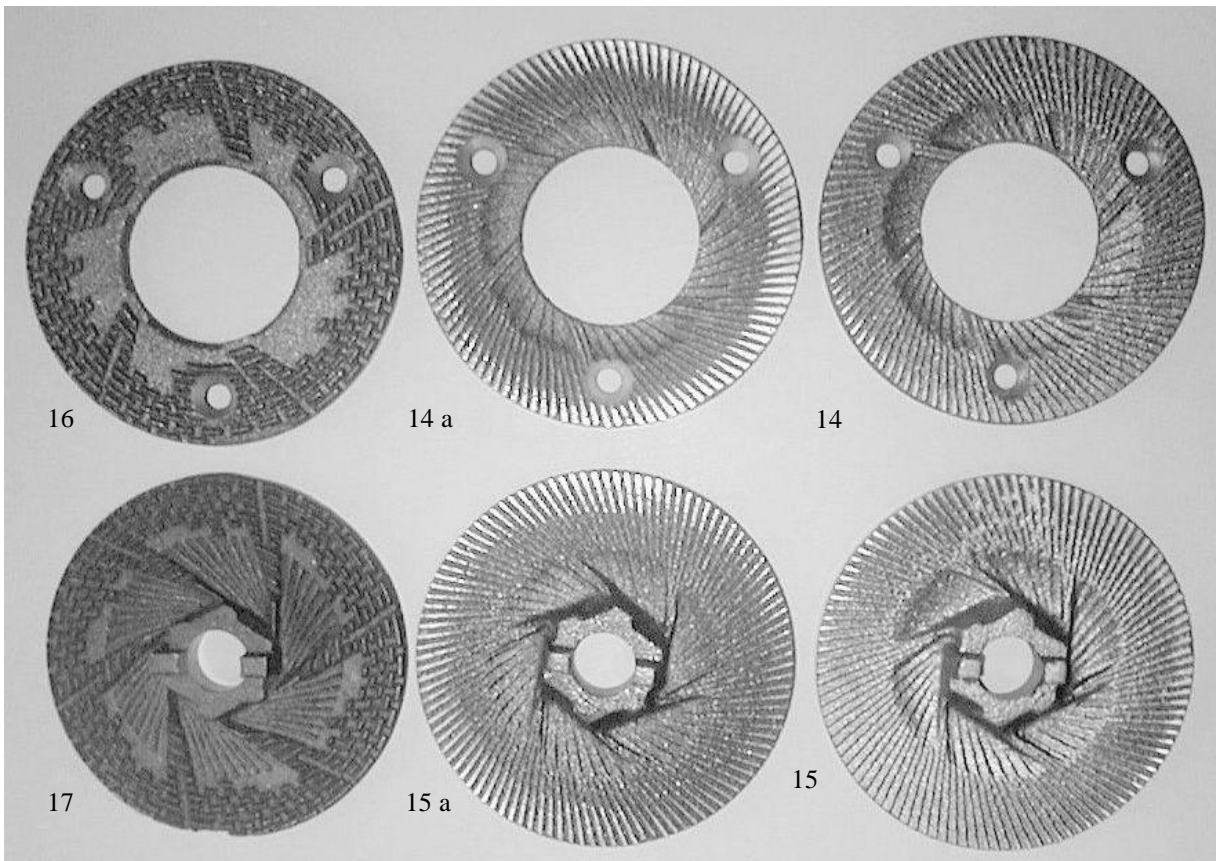

## Distance adjustment of discs

The distance between the discs is adjustable so the grinding fineness can be changed during operation.

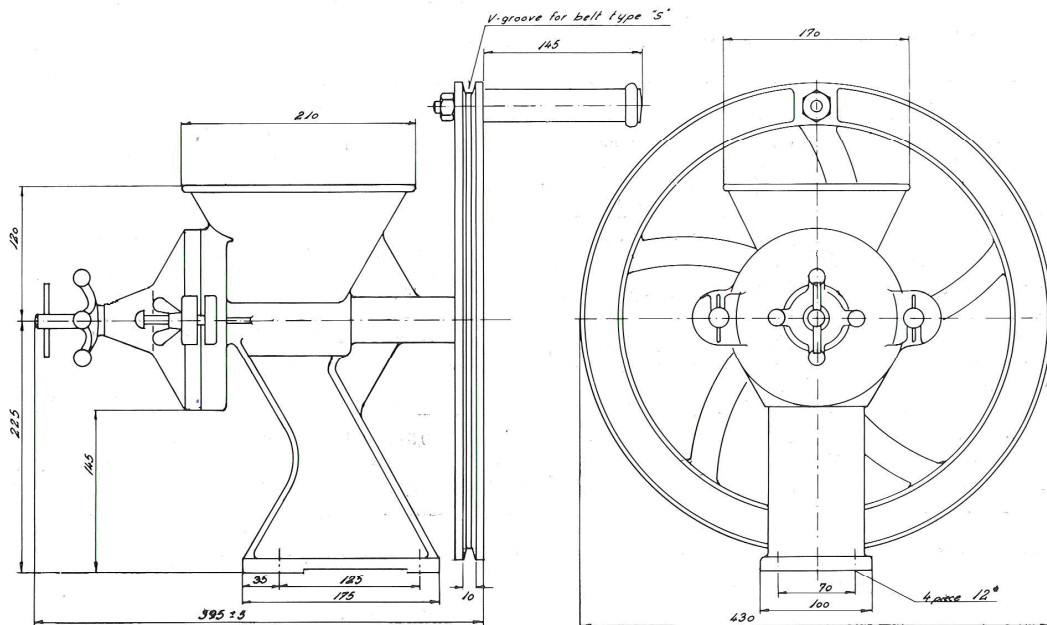

Sketch of Domestic Mill type 525.

Dwg. no. 5252. 25/11/01

---

Engsko A/S  
Tronholmen 10  
DK-8960 Randers SØ  
DENMARK

Phone +45 86 42 64 88  
Fax +45 86 41 36 22  
E-Mail [info@engsko.com](mailto:info@engsko.com)  
[www.unitedmillingsystems.com](http://www.unitedmillingsystems.com)